

EMC TEST REPORT

Applicant : Civan Makina Muh. Mim.Ins.Tic.Ltd.Sti
Address : Eskişehir/Odunpazarı 75. Yıl OSB Mah. 8.Cadde No:16, Turkey
Manufacturer : Guangzhou Sprsun New Energy Technology Development Co., Ltd.
Address : No.15 Tangxi Road, Yinsha Industrial Park, Xintang, Zengcheng,
Guangzhou 511338, China
EUT : Air Source Heat Pump
Model No : ARX-30DF32SP-3F, ARX-24DF32SP-3F, ARX-39DF32SP-3F, ARX-
25DF290SP-3F
Brand Name: : 
Report Number : PRMS2601055
Test Date : Jan 02-Jan 16, 2026
Date of Issue : Jan 17, 2026
Test Procedure Used:
EN IEC 55014-1:2021, EN IEC 55014-2: 2021
EN IEC 61000-3-2:2019+A1:2021,
: EN IEC 61000-3-3:2013+A1:2019+A2:2021
EN IEC 61000-3-11:2019+A1:2021, EN 61000-3-12:2011

This report shall not be reproduced except in full, without the written approval of PRMS, this document may be altered or revised by PRMS, personal only, and shall be noted in the revision of the document. The test report merely corresponds to the test sample. It is not permitted to copy extracts of these test result without the written permission of the test laboratory.

Prepared By : _____
(Yann)

Reviewed by : _____
(Leo Li)

Approved by : _____
(Kind yang)

TABLE OF CONTENTS

1- GENERAL INFORMATION	4
1.1 PRODUCT DESCRIPTION FOR EQUIPMENT UNDER TEST (EUT).....	4
1.2 TEST STANDARDS	5
1.3 TEST SUMMARY	5
1.4 TEST METHODOLOGY	6
1.5 TEST FACILITY	6
1.6 TEST EQUIPMENT LIST AND DETAILS	6
1.7 DESCRIPTION OF TEST MODES	8
2- SYSTEM TEST CONFIGURATION	9
2.1 JUSTIFICATION	9
2.2 EUT EXERCISE SOFTWARE	9
2.3 BASIC CONFIGURATION OF TEST SYSTEM.....	9
2.4 GENERAL DESCRIPTION OF TEST AUXILIARY	9
3- CONDUCTED DISTURBANCE AT THE MAINS TERMINALS	10
3.1 MEASUREMENT UNCERTAINTY	10
3.2 POWER LINE CONDUCTED EMISSION(FREQUENCY RANGE 150KHz-30MHz).....	10
3.3 EUT SETUP	10
3.4 INSTRUMENT SETUP	11
3.5 TEST PROCEDURE	11
3.6 TEST DETAIL AND TEST RESULT	12
4- RADIATED DISTURBANCES	15
4.1 MEASUREMENT UNCERTAINTY.....	15
4.2 LIMITS OF DISTURBANCE POWER MEASUREMENT (BELOW 1000MHz).....	15
4.3 EUT SETUP	16
4.4 TEST RECEIVER SETUP	16
4.5 TEST PROCEDURE	17
4.6 CORRECTED AMPLITUDE & MARGIN CALCULATION	17
4.7 TEST DETAIL AND TEST RESULT	18
5 – HARMONIC CURRENT TEST	21
5.1 APPLICATION OF HARMONIC CURRENT EMISSION	21
5.2 BLOCK DIAGRAM OF TEST SETUP:	21
5.3 TEST LIMIT	21
5.4 TEST PROCEDURE:	23
5.5 TEST RESULT:	23
6 – VOLTAGE FLUCTUATIONS AND FLICKER TEST	24
6.1 APPLICATION AND LIMIT OF VOLTAGE FLUCTUATIONS AND FLICKER TEST	24
6.2 BLOCK DIAGRAM OF TEST SETUP:	24
6.3 TEST PROCEDURE:	25
6.4 TEST RESULT:	25
7- EMC IMMUNITY TEST	26
7.1 GENERAL DESCRIPTION	26
7.2 THE PHENOMENA ALLOWED DURING AND AFTER TEST IN EACH CRITERION ARE CLEARLY STATED IN THE FOLLOWING TABLE ...	27
7.3 DEVIATIONS FROM THE STANDARD	27
8- IMMUNITY TEST RESULTS.....	28
8.1 ELECTROSTATIC DISCHARGE IMMUNITY TEST	28
8.1.1 TEST SPECIFICATION	28
8.1.2 TEST SETUP	28

8.1.3 TEST PROCEDURE	29
8.1.4 PERFORMANCE CRITERION REQUIRED & TEST RESULT	30
8.2 ELECTRICAL FAST TRANSIENT/BURST IMMUNITY TEST	31
8.2.1 TEST SPECIFICATION	31
8.2.2 TEST SETUP	31
8.2.3 TEST PROCEDURE	31
8.2.4 PERFORMANCE CRITERION REQUIRED & TEST RESULT	32
8.3 SURGE IMMUNITY TEST	33
8.3.1 TEST SPECIFICATION	33
8.3.2 TEST SETUP	33
8.3.3 TEST PROCEDURE	34
8.3.4 PERFORMANCE CRITERION REQUIRED & TEST RESULT	34
8.4 CONDUCTED SUSCEPTIBILITY TEST	35
8.4.1 TEST SPECIFICATION	35
8.4.2 TEST SETUP	35
8.4.3 TEST PROCEDURE	35
8.4.4 PERFORMANCE CRITERION REQUIRED & TEST RESULT	36
8.5 VOLTAGE DIPS, SHORT INTERRUPTIONS IMMUNITY TESTS	37
8.5.1 TEST SPECIFICATION	37
8.5.2 TEST SETUP	37
8.5.3 TEST PROCEDURE	38
8.5.4 PERFORMANCE CRITERION REQUIRED & TEST RESULT	38
8.6 RADIATED SUSCEPTIBILITY TEST	39
8.6.1 TEST SPECIFICATION	39
8.6.2 TEST SETUP	39
8.6.3 TEST PROCEDURE	39
8.6.4 PERFORMANCE CRITERION REQUIRED & TEST RESULT	40
APPENDIX A - EUT PHOTOGRAPHS	41

DRAFT

1- GENERAL INFORMATION

1.1 Product Description for Equipment under Test (EUT)

Client Information

Applicant:	Civan Makina Muh. Mim.Ins.Tic.Ltd.Sti
Address of applicant:	Eskişehir/Odunpazarı 75. Yıl OSB Mah. 8.Cadde No:16, Turkey
Manufacturer:	Guangzhou Sprsun New Energy Technology Development Co., Ltd.
Address of Manufacturer:	No.15 Tangxi Road, Yinsha Industrial Park, Xintang, Zengcheng, Guangzhou 511338, China

General Description of E.U.T

EUT Name:	Air Source Heat Pump
Trade Mark:	
Operating Mode.:	Mode 1: Power on
Model No:	ARX-30DF32SP-3F
Adding Model:	ARX-24DF32SP-3F, ARX-39DF32SP-3F, ARX-25DF290SP-3F
Power Supply:	Input: AC390-420V 3W-50Hz Power: 30 KW

Remark: * The test data gathered are from the production sample provided by the manufacturer.

1.2 Test Standards

The following Declaration of Conformity report of EUT is prepared in accordance with

- EN IEC 55014-1: 2021
- EN IEC 55014-2: 2021
- EN IEC 61000-3-2:2019+A1:2021
- EN IEC 61000-3-3:2013+A1:2019+A2:2021
- EN IEC 61000-3-11:2019+A1:2021
- EN 61000-3-12:2011
- Reference Standards:
- EN 61000-4-2:2009
- EN IEC 61000-4-3:2020
- EN 61000-4-4:2012
- EN 61000-4-5:2014+A1:2017
- EN IEC 61000-4-6:2023
- EN IEC 61000-4-11:2020/AC:2022

The objective of the manufacturer is to demonstrate compliance with the described standards above.

1.3 Test Summary

Table 1:

Standard	Test Items	Status
EN IEC 55014-1: 2021	Conducted Emission (150kHz to 30MHz)	<input checked="" type="checkbox"/>
	Radiated Disturbances (30MHz to 1000MHz)	<input checked="" type="checkbox"/>

Table 2:

Standard	Test Items	Status
EN IEC 61000-3-2:2019+A1:2021	Harmonic Current Test	<input checked="" type="checkbox"/>
EN 61000-3-3:2013+A2:2021 +AC:2022	Voltage Fluctuations and Flicker Test	<input checked="" type="checkbox"/>

Table 3:

Standard	Test Items	Status
EN IEC 55014-2: 2021	Test items as below listed	<input checked="" type="checkbox"/>
EN 61000-4-2:2009	Electrostatic discharge Immunity	<input checked="" type="checkbox"/>
EN IEC 61000-4-3:2020	Radiated Susceptibility (80MHz to 1GHz)	<input checked="" type="checkbox"/>

EN 61000-4-4:2012	Electrical Fast Transient/Burst Immunity	<input checked="" type="checkbox"/>
EN 61000-4-5:2014+A1:2017	Surge Immunity	<input checked="" type="checkbox"/>
EN IEC 61000-4-6:2023	Conducted Susceptibility (150kHz to 230MHz)	<input checked="" type="checkbox"/>
EN IEC 61000-4-11:2020 /AC:2022	Voltage Dips, Short Interruptions Immunity	<input checked="" type="checkbox"/>

Note: Indicates that the test is applicable, Indicates that the test is not applicable
 (1) Not applicable, Applicable only to CPE xDSL ports.

1.4 Test Methodology

All measurements contained in this report were conducted with CISPR 16-1-1: 2019, Radio disturbance and immunity measuring apparatus – Measuring apparatus, and CISPR 16-2-3: 2010, Method of measurement of disturbances and immunity.

1.5 Test Facility

ShenZhen Promise Test Technology Co., Ltd.

(Add.): 103, Building 1, Yibaolai Industrial City, Qiaotou Community, Fuhai Street, Baoan District, Shenzhen, Guangdong, China

1.6 Test Equipment List and Details

CONDUCTED EMISSION

Item	Kind of Equipment	Manufacturer	Type No.	Serial No.	Last calibration	Calibrated until	Calibration period
1	LISN	R&S	ENV216	101334	Apr.2,2026	Apr.1,2026	1 year
2	LISN	SCHWARZBECK	NNLK 8129	8129267	Apr.2,2026	Apr.1,2026	1 year
3	Pulse Limiter	SCHWARZBECK	VTSD 9561F	9716	Apr.2,2026	Apr.1,2026	1 year
4	50Ω SWITCH	ANRITSU CORP	MP59B	6200983704	Apr.2,2026	Apr.1,2026	1 year
5	TEST CABLE	N/A	C01	N/A	Apr.2,2026	Apr.1,2026	1 year
6	TEST CABLE	N/A	C02	N/A	Apr.2,2026	Apr.1,2026	1 year
7	TEST CABLE	N/A	C03	N/A	Apr.2,2026	Apr.1,2026	1 year
8	EMI Test Receiver	R&S	ESCI	101318	Apr.2,2026	Apr.1,2026	1 year
9	Passive Voltage Probe	ESH2-Z3	R&S	100173	Apr.2,2026	Apr.1,2026	1 year
10	Triple-Loop Antenna	EVERFINE	LIA-2	11020016	Apr.2,2026	Apr.1,2026	1 year

11	Absorbing Clamp	R&S	MDS-21	100423	Apr.2,2026	Apr.1,2026	1 year
----	-----------------	-----	--------	--------	------------	------------	--------

RADIATED TEST SITE

Item	Kind of Equipment	Manufacturer	Type No.	Serial No.	Last calibration	Calibrated until	Calibration period
1	Bilog Antenna	TESEQ	CBL6111D	31437	Apr.2,2026	Apr.1,2026	1 year
2	Test Cable	N/A	R-01	N/A	Apr.2,2026	Apr.1,2026	1 year
3	Test Cable	N/A	R-02	N/A	Apr.2,2026	Apr.1,2026	1 year
4	EMI Test Receiver	Rohde&Schwarz	ESVD	847312/008	Apr.2,2026	Apr.1,2026	1 year
5	Antenna Mast	EM	SC100_1	N/A	N/A	N/A	N/A
6	Turn Table	EM	SC100	060533	N/A	N/A	N/A
7	50Ω Switch	Anritsu Corp	MP59B	6200983705	Apr.2,2026	Apr.1,2026	1 year
8	SPECTRUM ANALYZER	Aglient	E4407B	160400005	Apr.2,2026	Apr.1,2026	1 year
9	HORN ANTENNA	EM	EM-AH-10180	201071402	Apr.2,2026	Apr.1,2026	1 year
10	AMPLIFIER	EM	EM-30130	060536	Apr.2,2026	Apr.1,2026	1 year

HARMONICS AND FILCK

Item	Kind of Equipment	Manufacturer	Type No.	Serial No.	Last calibration	Calibrated until	Calibration period
1	Harmonic & Flicker	EM TEST	DPA500	0303-08	Apr.2,2026	Apr.1,2026	1 year
2	AC Power Source	EM TEST	ACS500	0203-06	Apr.2,2026	Apr.1,2026	1 year

ESD

Item	Kind of Equipment	Manufacturer	Type No.	Serial No.	Last calibration	Calibrated until	Calibration period
1	ESD TEST GENERATOR	SCHAFFNER	NSG438	858	Apr.2,2026	Apr.1,2026	1 year

RS

Item	Kind of Equipment	Manufacturer	Type No.	Serial No.	Last calibration	Calibrated until	Calibration
------	-------------------	--------------	----------	------------	------------------	------------------	-------------

							period
1	Signal Generator	R&S	SMT 06	832080/007	Apr.2,2026	Apr.1,2026	1 year
2	Log-Bicon Antenna	Schwarzbeck	VULB9161	4022	Apr.2,2026	Apr.1,2026	1 year
3	Power Amplifier	AR	150W1000M1	320946	Apr.2,2026	Apr.1,2026	1 year
4	Microwave Horn Antenna	AR	AT4002A	321467	Apr.2,2026	Apr.1,2026	1 year
5	Power Amplifier	AR	25S1G4A	308598	Apr.2,2026	Apr.1,2026	1 year

SURGE, EFT/BURST, VOLTAGE INTERRUPTION/DIPS

Item	Kind of Equipment	Manufacturer	Type No.	Serial No.	Last calibration	Calibrated until	Calibration period
1	Surge Generator	EVERFINE	EMS61000-5A	1101002	Apr.2,2026	Apr.1,2026	1 year
2	DIPS Generator	EVERFINE	EMS61000-11K	1011002	Apr.2,2026	Apr.1,2026	1 year
3	EFT/B Generator	EVERFINE	EMS61000-4A-V2	1012005	Apr.2,2026	Apr.1,2026	1 year

1.7 DESCRIPTION OF TEST MODES

Pretest Mode	Description
Mode 1	power on
/	/

For Conducted Test	
Final Test Mode	Description
Mode 1	power on
/	/

For Radiated Test	
Final Test Mode	Description
Mode 1	power on
/	/

For EMS Test	
Final Test Mode	Description
Mode 1	power on
/	/

2- SYSTEM TEST CONFIGURATION

2.1 Justification

The system was configured for testing in a typical fashion (as normally used by a typical user).

2.2 EUT Exercise Software

The EUT exercising program used during radiated and conducted testing was designed to exercise the various system components in a manner similar to a typical use. The software offered by manufacture, can let the EUT being Charge

2.3 Basic Configuration of Test System

Emission: The equipment under test (EUT) was configured to measure its highest possible radiation level. The test modes were adapted accordingly in reference to the Operating Instructions.

Immunity: The equipment under test (EUT) was configured to the representative operating mode and conditions.

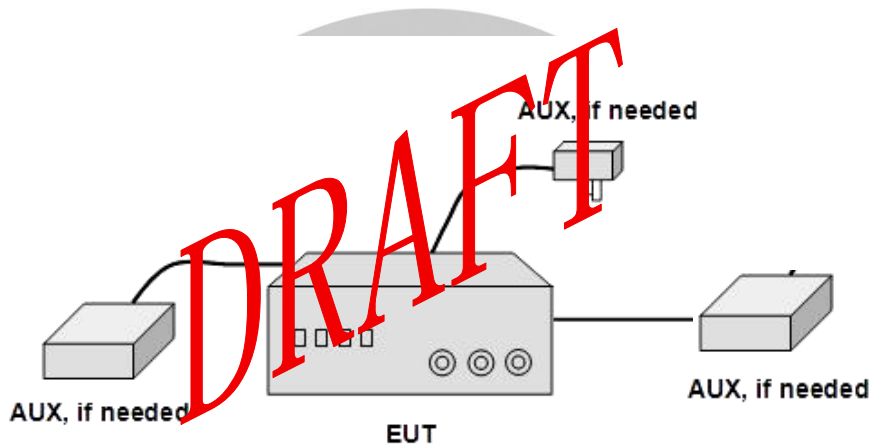

2.4 General Description of Test Auxiliary

EUT Cable List and Details			
Cable Description	Length (m)	Shielded/Unshielded	With / Without Ferrite
/	/	/	/
/	/	/	/

Auxiliary Equipment List and Details			
Description	Manufacturer	Model	Serial Number
/	/	/	/
/	/	/	/

3- CONDUCTED DISTURBANCE AT THE MAINS TERMINALS

3.1 Measurement Uncertainty

All measurements involve certain levels of uncertainties, especially in field of EMC. The factors contributing to uncertainties are spectrum analyzer, cable loss, and LISN. The Treatment of Uncertainty in EMC Measurements, the best estimate of the uncertainty of any conducted emissions measurement is ± 2.7 dB.

3.2 POWER LINE CONDUCTED EMISSION(Frequency Range 150KHz-30MHz)

Frequency Range (MHz)	At mains terminals		At load terminals and additional terminals	
	Quasi-peak (dBuV)	Average (dBuV)	Quasi-peak (dBuV)	Average (dBuV)
0.15 -0.5	66 - 56 *	56 - 46 *	80.00	70.00
0.50 -5.0	56.00	46.00	74.00	64.00
5.0 -30.0	60.00	50.00	74.00	64.00

3.3 EUT Setup

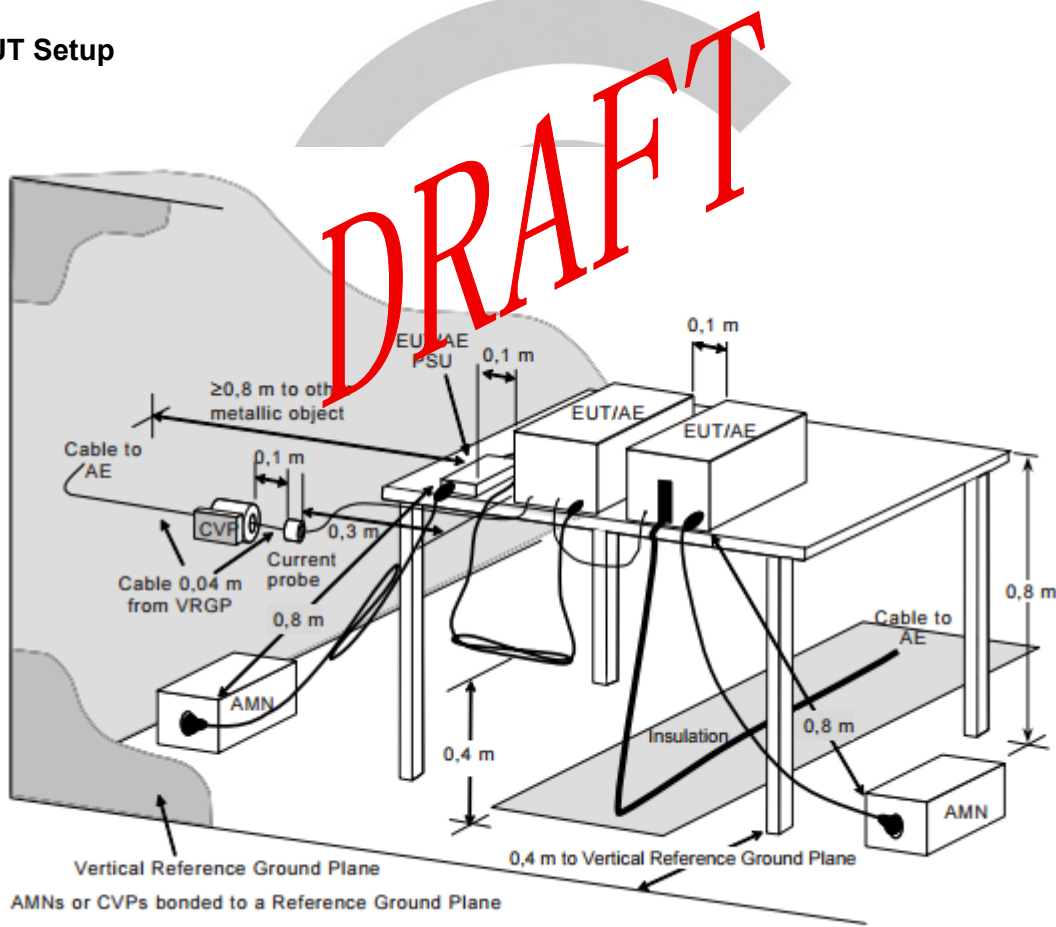

The setup of EUT is according with CISPR 16-1-1: 2019, CISPR 16-2-3: 2010 measurement procedure. The specification used was the EN 55014-1 limits.

The EUT was placed center and the back edge of the test table.

The AV cables were draped along the test table and bundled to 30-40cm in the middle.

The spacing between the peripherals was 10 cm.

Maximum emission emitted from EUT was determined by manipulating the EUT, support equipment, interconnecting cables and varying the mode of operation and the levels in the final result of the test were recorded with the EUT running in the operating mode that maximum emission was emitted.

3.4 Instrument Setup

The test receiver was set with the following configurations:

Test Receiver Setting:

Frequency Range.....150 KHz to 30 MHz
Detector.....Peak & Quasi-Peak & Average
Sweep Speed.....Auto
IF Band Width.....9 KHz

3.5 Test Procedure

1. During the conducted emission test, the EUT power cord was connected to the auxiliary outlet of the first Artificial Mains.
2. Maximizing procedure was performed on the six (6) highest emissions to ensure EUT compliance using all installation combination.
3. All data was recorded in the peak detection mode. Quasi-peak and Average readings were only performed when an emission was found to be marginal (within -10 dB μ V of specification limits). Quasi-peak readings are distinguished with a "QP". Average readings are distinguished with a "AV".

3.6 Test Detail And Test Result

EUT:	Air Source Heat Pump	Model Name:	ARX-30DF32SP-3F
Temperature	24 °C	Relative Humidity:	55%
Pressure:	1025hPa	Test Line:	L1
Test Mode	Mode 1	Test Voltage:	AC380V/50Hz

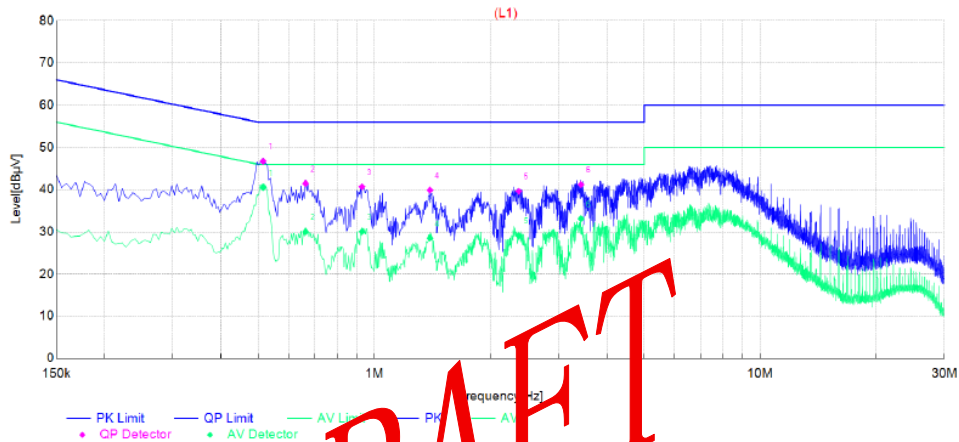

Final Data List												
NO.	Frequency	QP	AVG.	Factor	QP	AVG.	QP	AVG.	QP	AVG.	Line	Remark
		Reading	Reading		Result	Result	Limit	Limit	Margin	Margin		
1	0.5145	36.50	30.28	10.24	46.74	40.52	56.00	46.00	9.26	5.48	L1	PASS
2	0.663	31.25	19.83	10.21	41.46	30.04	56.00	46.00	14.54	15.96	L1	PASS
3	0.9285	30.48	19.89	10.21	40.69	30.10	56.00	46.00	15.31	15.90	L1	PASS
4	1.392	29.66	18.31	10.23	39.89	28.54	56.00	46.00	16.11	17.46	L1	PASS
5	2.3685	29.34	18.82	10.30	39.64	29.12	56.00	46.00	16.36	16.88	L1	PASS
6	3.4305	30.86	22.78	10.35	41.21	33.13	56.00	46.00	14.79	12.87	L1	PASS

Note:1. Result (dBµV) = Reading (dBµV) + Factor (dB).

2. Factor (dB) = Cable loss (dB) + LISN Factor (dB).

EUT:	Air Source Heat Pump	Model Name:	ARX-30DF32SP-3F
Temperature	24 °C	Relative Humidity:	55%
Pressure:	1025hPa	Test Line:	L2
Test Mode	Mode 1	Test Voltage:	AC380V/50Hz

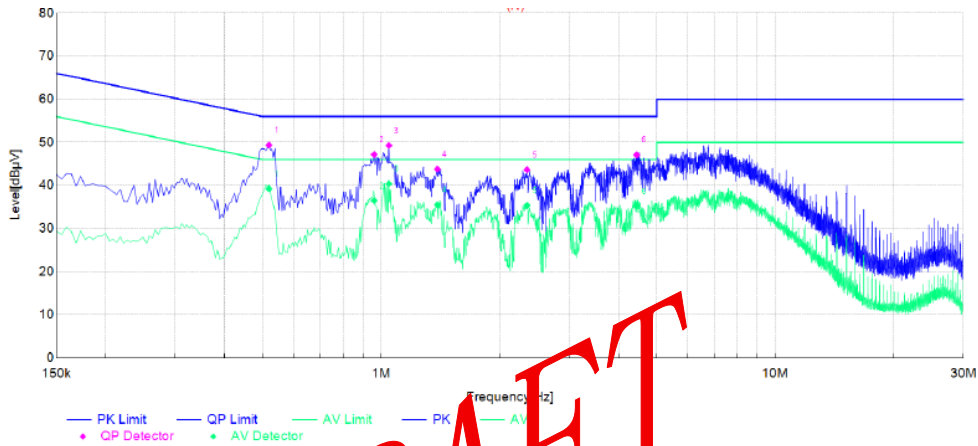

Final Data List												
NO.	Frequency	QP	AVG.	Factor	QP	AVG.	QP	AVG.	QP	AVG.	Line	Remark
		Reading	Reading		Result	Result	Limit	Limit	Margin	Margin		
1	0.519	39.12	28.97	10.24	49.36	39.21	56.00	46.00	6.64	6.79	L2	PASS
2	0.96	37.00	26.29	10.20	47.20	36.49	56.00	46.00	8.80	9.51	L2	PASS
3	1.0455	39.07	30.19	10.20	49.27	40.39	56.00	46.00	6.73	5.61	L2	PASS
4	1.3875	33.56	25.30	10.23	43.79	35.53	56.00	46.00	12.21	10.47	L2	PASS
5	2.346	33.36	25.09	10.29	43.65	35.38	56.00	46.00	12.35	10.62	L2	PASS
6	4.452	36.74	24.88	10.36	47.10	35.24	56.00	46.00	8.90	10.76	L2	PASS

Note:1. Result (dBμV) = Reading (dBμV) + Factor (dB).

2. Factor (dB) = Cable loss (dB) + LISN Factor (dB).

EUT:	Air Source Heat Pump	Model Name:	ARX-30DF32SP-3F
Temperature	24 °C	Relative Humidity:	55%
Pressure:	1025hPa	Test Line:	L3
Test Mode	Mode 1	Test Voltage:	AC380V/50Hz

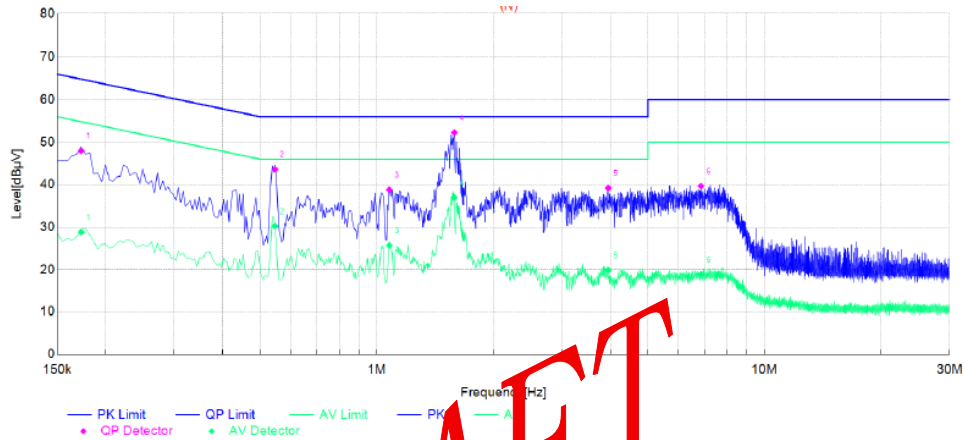

Final Data List												
NO.	Frequency	QP Reading	AVG Reading	Factor	QP Result	AVG Result	QP Limit	AVG Limit	QP Margin	AVG Margin	Line	Remark
1	0.1725	37.72	18.00	10.24	47.96	28.84	64.84	54.84	16.88	26.00	L3	PASS
2	0.546	33.40	20.04	10.22	43.62	30.26	56.00	46.00	12.38	15.74	L3	PASS
3	1.077	28.60	15.52	10.21	38.81	25.73	56.00	46.00	17.19	20.27	L3	PASS
4	1.5855	42.02	26.76	10.24	52.26	37.00	56.00	46.00	3.74	9.00	L3	PASS
5	3.9525	28.83	9.50	10.37	39.20	19.87	56.00	46.00	16.80	26.13	L3	PASS
6	6.8595	29.16	8.40	10.51	39.67	18.91	60.00	50.00	20.33	31.09	L3	PASS

Note:1. Result (dBµV) = Reading (dBµV) + Factor (dB).

2. Factor (dB) = Cable loss (dB) + LISN Factor (dB).

4- RADIATED DISTURBANCES

4.1 Measurement Uncertainty

Test Site: 3m SAC

All measurements involve certain levels of uncertainties, especially in field of EMC. The factors contributing to uncertainties are spectrum analyzer, cable loss, antenna factor calibration, antenna directivity, antenna factor variation with height, antenna phase center variation, antenna factor frequency interpolation, measurement distance variation, site imperfections, mismatch (average), and system repeatability.

The Treatment of Uncertainty in EMC Measurements, the best estimate of the uncertainty of a radiation emissions measurement is as below table.

Measurement	Frequency Range	Expanded Uncertainty (k=2)	Ucisp
Radiated Emissions, 3m	30-200MHz HP	3.6 dB	6.3 dB
Radiated Emissions, 3m	30-200MHz VP	4.5 dB	6.3 dB
Radiated Emissions, 3m	200-1000MHz HP	3.7 dB	6.3 dB
Radiated Emissions, 3m	200-1000MHz VP	3.7 dB	6.3 dB
Radiated Emissions, 3m	1-26 GHz	5.4 dB	5.5 dB

As shown in the table above our radiated emissions U_{lab} is less than the corresponding U_{CISPR} reference value in CISPR 16-4-2 Table 1, hence the compliance of the product is only based on the measured value, and no measurement uncertainty correction is required, based on CISPR 22 and CISPR 11 (for 2006 and later revisions) Clause 11.

4.2 LIMITS OF DISTURBANCE POWER MEASUREMENT (Below 1000MHz)

FREQUENCY (MHz)	At 10m	At 3m
	dBuV/m	dBuV/m
30 – 230	30	40
230 – 1000	37	47

4.3 EUT Setup

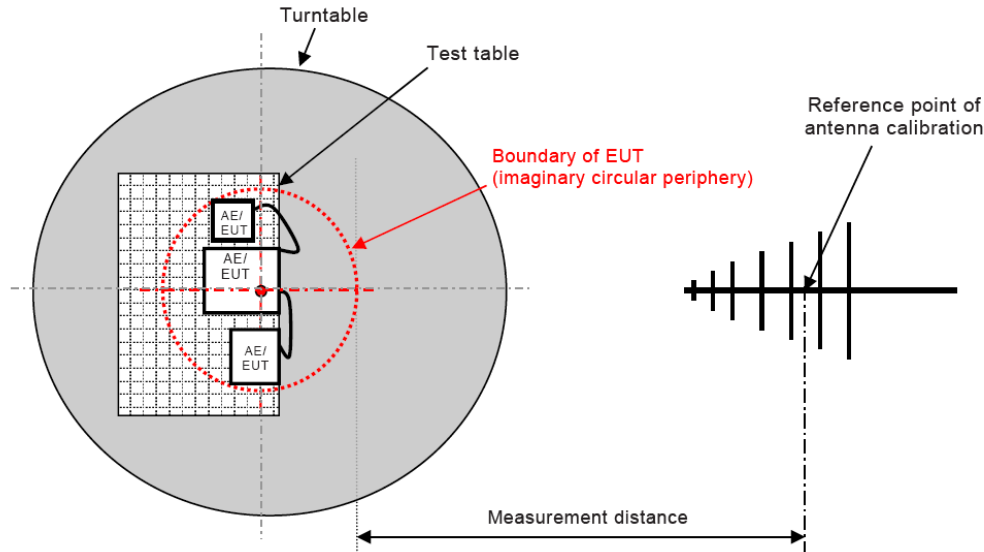

The radiated emission tests were performed in the open area 30-meter test site, using the setup accordance with the CISPR 16-1-1: 2019, CISPR 16-2-3: 2010. The specification used was EN 55014-1: 2020

The EUT was placed on the center of the test table.

Maximum emission emitted from EUT was determined by manipulating the EUT, support equipment, interconnecting cables and varying the mode of operation and the levels in the final result of the test were recorded with the EUT running in the operating mode that maximum emission was emitted.

4.4 Test Receiver Setup

According to EN 55014-1: 2020 rules, the frequency was investigated from 30 to 1000 MHz. During the radiated emission test, the test receiver was set with the following configurations:

Detector.....Peak & Quasi-Peak
 IF Band Width.....120KHz
 Frequency Range.....30MHz to 1000MHz
 Turntable Rotated.....0 to 360 degrees

Antenna Position:

Height.....1m to 4m
 Polarity.....Horizontal and Vertical

4.5 Test Procedure

1. Maximizing procedure was performed on the highest emissions to ensure that the EUT complied with all installation combinations.
2. All data was recorded in the peak detection mode. Quasi-peak readings performed only when an emission was found to be marginal (within -10 dB μ V of specification limits), and are distinguished with a "QP" in the data table.

4.6 Corrected Amplitude & Margin Calculation

Sample Calculation:

The field strength is calculated by adding the Antenna Factor and Cable Factor, and subtracting the Amplifier Gain (if any) from the measured reading. The basic equation with a sample calculation is as follows:

$$FS = RA + AF + CF - AG$$

Where FS = Field Strength in dB μ V/m
RA = Receiver Amplitude (including preamplifier) in dB μ V
CF = Cable Attenuation Factor in dB
AF = Antenna Factor in dB
AG = Amplifier Gain in dB

In the following table(s), the reading shown on the data table reflects the preamplifier gain. An example for the calculations in the following table is as follows.

Assume a receiver reading of 52.0 dB μ V is obtained. The antenna factor of 7.4 dB and cable factor of 1.6 dB is added.

The amplifier gain of 29 dB is subtracted, giving a field strength of 32 dB μ V/m. This value in dB μ V/m was converted to its corresponding level in V/m.

RA = 52.0
dB μ V AF = 7.4
dB/m
CF = 1.6 dB
AG = 29.0 dB
FS = 32 dB μ V/m

To convert from dB μ V to μ V or mV the following was

used: $UF = 10^{(NF / 20)}$

where UF = Net Reading in μ V
NF = Net Reading in dB μ V

4.7 Test Detail And Test Result

Radiated Emission Test Detail of Below 1GHz

EUT:	HEAT PUMP	Model Name:	ARX-30DF32SP-3F
Temperature	24 °C	Relative Humidity:	55%
Pressure:	1025hPa	Test Polarity:	Horizontal
Test Mode	Mode 2	Test Voltage:	AC380V/50Hz

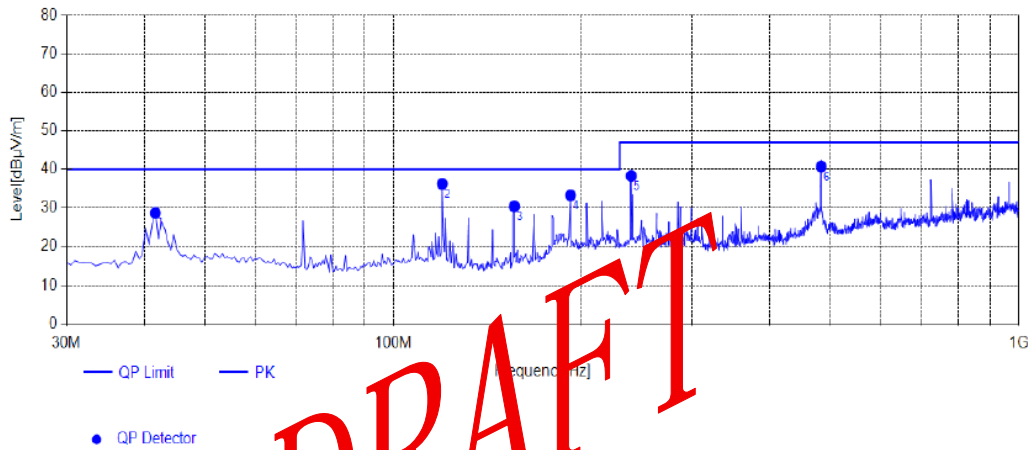

Quasi-peak Final Data List										
NO.	Frequency [MHz]	Reading [dBµV/m]	Factor [dB]	Result [dBµV/m]	Limit [dBµV/m]	Margin [dB]	Height [cm]	Angle [°]	Polarity	Remark
1	41.64	40.4	-11.68	28.72	40.00	11.28	208	304	Horizontal	PASS
2	119.725	48.9	-12.64	36.26	40.00	3.74	204	261	Horizontal	PASS
3	156.1	43.98	-13.55	30.43	40.00	9.57	193	43	Horizontal	PASS
4	191.99	44.22	-10.93	33.29	40.00	6.71	191	113	Horizontal	PASS
5	240.005	47.37	-9.07	38.30	47.00	8.70	182	228	Horizontal	PASS
6	482.99	43.49	-2.75	40.74	47.00	6.26	173	358	Horizontal	PASS

Note:1. Result (dBµV/m) = Reading(dBµV/m) + Factor (dB) .

2. Factor (dB) = Antenna Factor (dB/m) + Cable loss (dB) - Pre Amplifier gain (dB).

Radiated Emission Test Data of Below 1GHz

EUT:	HEAT PUMP	Model Name:	ARX-30DF32SP-3F
Temperature	24 °C	Relative Humidity:	55%
Pressure:	1025hPa	Test Polarity:	Vertical
Test Mode	Mode 2	Test Voltage:	AC380V/50Hz

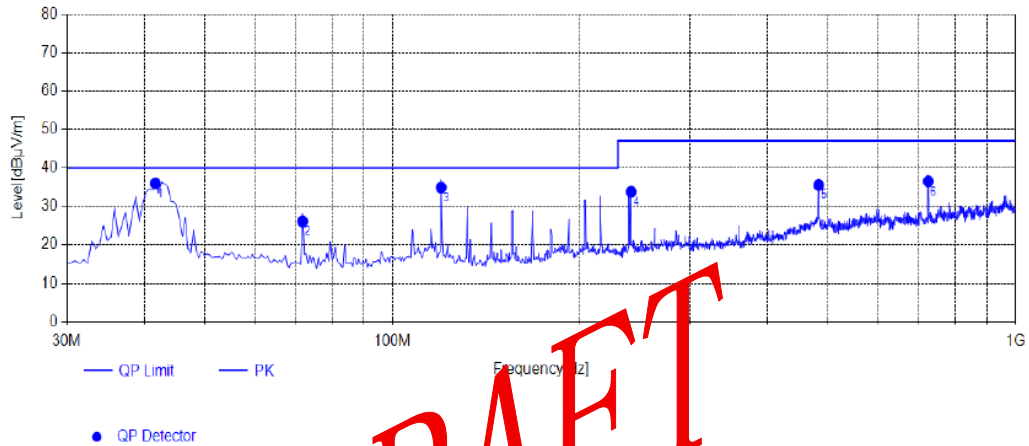

Quasi-peak Final Data List										
NO.	Frequency [MHz]	Reading [dBµV/m]	Factor [dB]	Result [dBµV/m]	Limit [dBµV/m]	Margin [dB]	Height [cm]	Angle [°]	Polarity	Remark
1	41.64	47.67	-11.68	35.99	40.00	4.01	106	274	Vertical	PASS
2	71.71	40.09	-13.98	26.11	40.00	13.89	105	158	Vertical	PASS
3	119.725	47.55	-12.64	34.91	40.00	5.09	115	85	Vertical	PASS
4	241.46	42.82	-9.03	33.79	47.00	13.21	109	46	Vertical	PASS
5	482.99	38.26	-2.75	35.51	47.00	11.49	107	320	Vertical	PASS
6	724.52	35.76	0.76	36.52	47.00	10.48	103	357	Vertical	PASS

Note:1. Result (dBµV/m) = Reading(dBµV/m) + Factor (dB) .

2. Factor (dB) = Antenna Factor (dB/m) + Cable loss (dB) - Pre Amplifier gain (dB).

Radiated Emission Test Detail of Above 1GHz

EUT:	HEAT PUMP	Model Name:	ARX-30DF32SP-3F
Temperature	24 °C	Relative Humidity:	55%
Pressure:	1025hPa	Test Polarity:	Horizontal
Test Mode	Mode 2	Test Voltage:	AC380V/50Hz

The EUT operating frequency is lower than 108MHz, Not Applicable.



5– HARMONIC CURRENT TEST

5.1 Application of Harmonic Current Emission

Compliance to these standards ensures that tested equipment will not generate harmonic currents at levels that cause unacceptable degradation of the main environment. This directly contributes to meeting compatibility levels established in other EMC standards, which defines compatibility levels for low-frequency conducted disturbances in low-voltage supply systems.

5.2 Block Diagram of Test Setup:

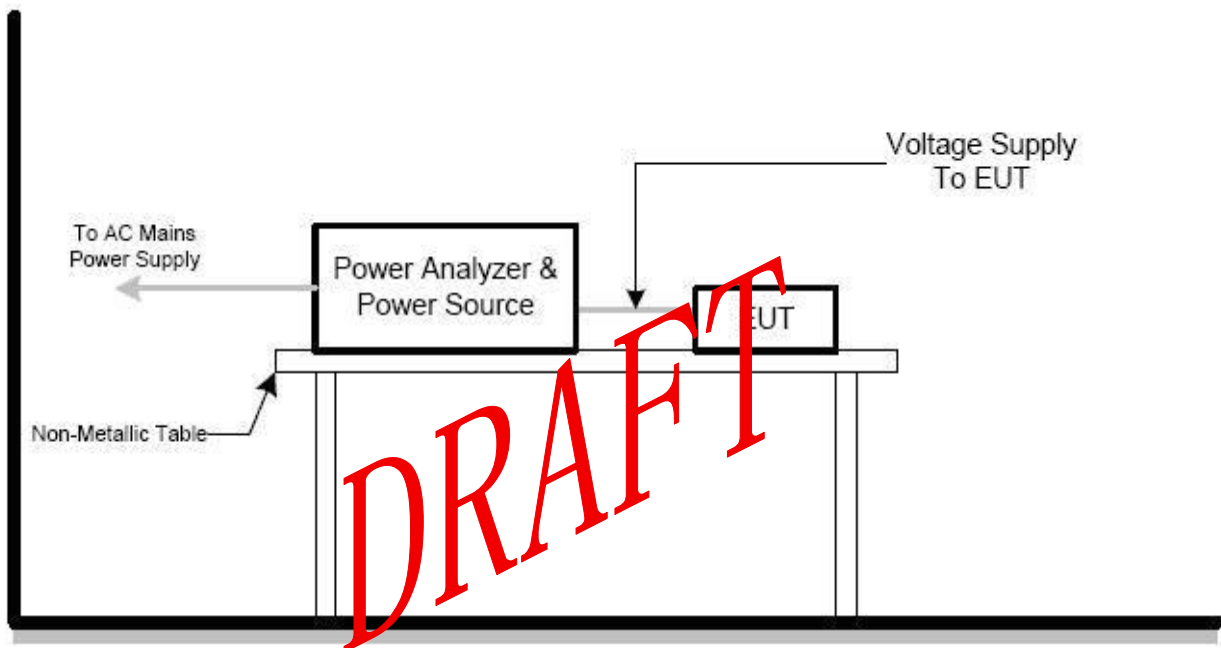

5.3 Test Limit

Class A equipment

Harmonic order n	Maximum permissible harmonic current A
Odd harmonics	
3	2,30
5	1,14
7	0,77
9	0,40
11	0,33
13	0,21
$15 \leq n \leq 39$	$0,15 \frac{15}{n}$
Even harmonics	
2	1,08
4	0,43
6	0,30
$8 \leq n \leq 40$	$0,23 \frac{8}{n}$

Class B equipment

not exceed the values given in Class A limit multiplied by a factor of 1,5

Class C equipment

Active input power >25 W

Harmonic order n	Maximum permissible harmonic current expressed as a percentage of the input current at the fundamental frequency %
2	2
3	$30 \cdot \lambda^b$
5	10
7	7
9	5
$11 \leq n \leq 39$ (odd harmonics only)	3

^a For some Class C products, other emission limits apply (see 7.4).
^b λ is the circuit power factor.

Active input power $5W \leq 25 W$

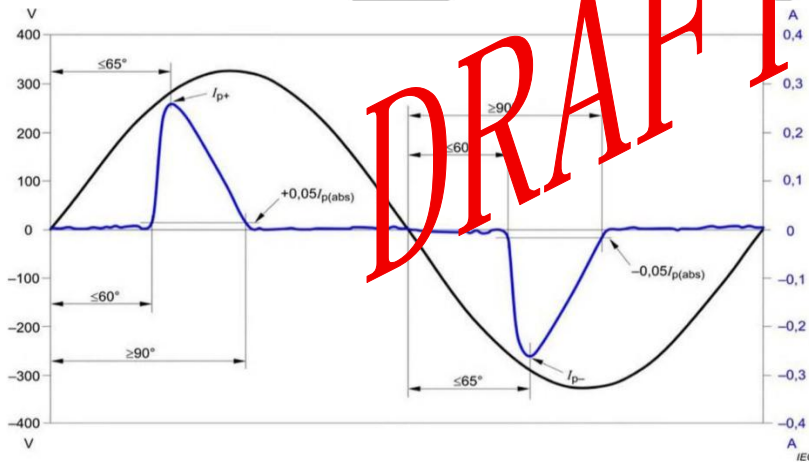

For lighting equipment with a rated power of $5W \leq 25W$, one of the following three

- 1 requirements shall be met The harmonic current should not exceed the limit values related to power in the second column of Table 3, or
- 2 The third harmonic current expressed as a percentage of the fundamental current should not exceed 86%, and the fifth harmonic current should not exceed 61%. At the same time, when the zero crossing point of the fundamental power supply voltage is used as a reference 0, the input current waveform should reach the current value at or before 60° , peak at or before 65° , and cannot decrease below the current value before 90° . The current value is equal to 5% of the maximum absolute peak value within the measurement window. The phase angle measurement value is determined within the period including the absolute peak value, as shown in Figure 2. Current components with frequencies higher than 9kHz should not affect this evaluation [filters similar to those described in 5.3 of 1EX61000-4-7:2002 and its Amd1 (2008) can be used]

3 THD should not exceed 70%. The percentage of fundamental current should not exceed 35% for the 3rd harmonic current, 25% for the 5th harmonic current, 30% for the 7th harmonic current, 20% for the 9th and 11th harmonic currents, and 5% for the 2nd harmonic current.

Class D equipment

Harmonic order n	Maximum permissible harmonic current per watt mA/W	Maximum permissible harmonic current A
3	3,4	2,30
5	1,9	1,14
7	1,0	0,77
9	0,5	0,40
11	0,35	0,33
$13 \leq n \leq 39$ (odd harmonics only)	$\frac{3,85}{n}$	See Table 1

5.4 Test Procedure:

1. The EUT was placed on the top of a wooden table 0.8 meters above the ground and operated to produce the maximum harmonic components under normal operating conditions for each successive harmonic component in turn.
2. The correspondent test program of test instrument to measure the current harmonics emanated from EUT is chosen. The measure time shall be not less than the time necessary for the EUT to be exercised.

5.5 Test Result:

Passed Not Applicable

Note 1: Equipment with a rated power of 75W or less, other than lighting equipment.

NOTE 2 This value may be reduced from 75 W to 50 W in the future, subject to approval by National Committees at that time.

- professional equipment with a total rated power greater than 1 kW;
- symmetrically controlled heating elements with a rated power less than or equal to 200 W;
- independent dimmers for incandescent lamps with a rated power less than or equal to 1 kW.

6 – VOLTAGE FLUCTUATIONS AND FLICKER TEST

6.1 Application and Limit of Voltage Fluctuations and Flicker Test

Compliance to these standards ensures that tested equipment will not generate flickers and voltage change at levels that cause unacceptable degradation of the main environment. This directly contributes to meeting compatibility levels established in other EMC standards, which defines compatibility levels for low-frequency conducted disturbances in low-voltage supply systems.

Test Item	Limit	Remark
Pst	1.0	Pst means short-term flicker indicator.
Plt	0.65	Plt means long-term flicker indicator.
Tdt (ms)	500	Tdt means maximum time that dt exceeds 3 %.
dmax (%)	4%	dmax means maximum relative voltage change.
dc (%)	3.3%	dc means relative steady-state voltage change

6.2 Block Diagram of Test Setup:

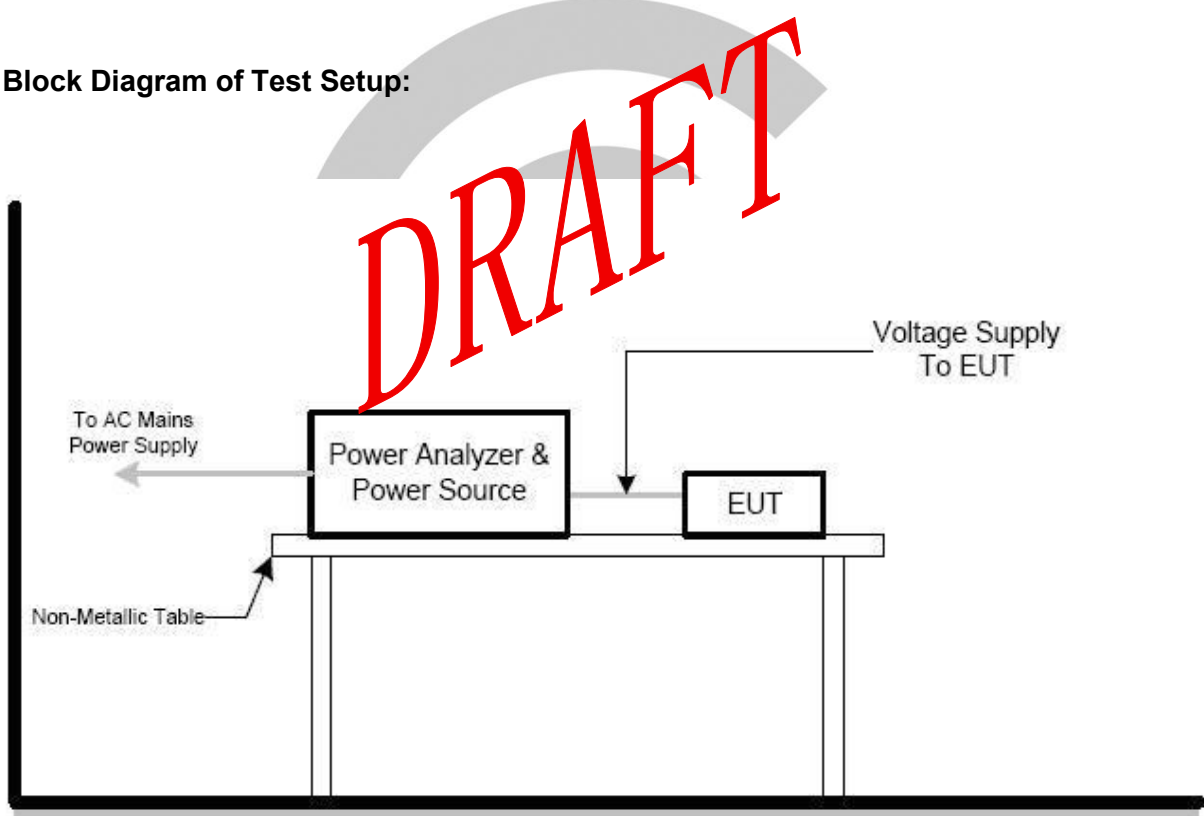

6.3 Test Procedure:

1. The EUT was placed on the top of a wooden table 0.8 meters above the ground and operated to produce the most unfavorable sequence of voltage changes under normal operating conditions.
2. During the flick measurement, the measure time shall include that part of whole operation cycle in which the EUT produce the most unfavorable sequence of voltage changes. The observation period for short-term flicker indicator is 10 minutes and the observation period for long-term flicker indicator is 2 hours.

6.4 Test Result:

Passed Not Applicable

Maximum Flicker results			
Test Item	EUT values	Limit	Result
Pst	0.53	1.00	Pass
dc [%]	1.86	3.30	Pass
dmax [%]	1.94	4.00	Pass
dt [s]	0.31	0.50	Pass

DRAFT

7- EMC IMMUNITY TEST

7.1 General Description

Product Standard	EN 55014-2	
Basic Standard, Specification, and Performance Criterion required	EN 61000-4-2	Electrostatic Discharge – ESD: $\pm 8\text{kV}$ air discharge, $\pm 4\text{kV}$ Contact discharge, Performance Criterion B
	EN 61000-4-3	Radio-Frequency Electromagnetic Field Susceptibility Test – RS: 80 ~ 1000 MHz, 3V/m, 80% AM (1kHz), Performance Criterion A
	EN 61000-4-4	Electrical Fast Transient/Burst - EFT, Power line: $\pm 1\text{kV}$, Signal line: $\pm 0.5\text{kV}$, Performance Criterion B
	EN 61000-4-5	Surge Immunity Test: 1.2/50 us Open Circuit Voltage, 8 /20 us Short Circuit Current, Power Line: line to line $\pm 1\text{ kV}$, line to ground $\pm 2\text{ kV}$ Signal line: line to ground: outdoor: 1kV indoor: $\pm 0.5\text{kV}$ Performance Criterion B
	EN 61000-4-6	Conducted Radio Frequency Disturbances Test – CS: 0.15 ~ 23 MHz, 3Vrms, 80% AM, 1kHz, Performance Criterion A
	EN 61000-4-11	Voltage Dips: 1) 0% residual for 0.5 cycle, Performance Criterion C 2) 40% residual for 10 cycles(50Hz), 12 cycles(60Hz), Performance Criterion C 3) 70% residual for 25 cycles(50Hz), 30 cycles(60Hz), Performance Criterion C

7.2 The phenomena allowed during and after test in each criterion are clearly stated in the following table

Performance criteria		
Criteria	During test	After test
A	Shall operate as intended. May show degradation of performance (see note1). Shall be no loss of function. Shall be no unintentional transmissions.	Shall operate as intended. Shall be no degradation of performance (see note 2). Shall be no loss of function. Shall be no loss of stored data or user programmable functions.
B	May show loss of function (one or more). May show degradation of performance (see note 1). No unintentional transmissions.	Functions shall be self-recoverable. Shall operate as intended after recovering. Shall be no degradation of performance (see note 2). Shall be no loss of stored data or user programmable functions.
C	May be loss of function (one or more).	Functions shall be recoverable by the operator. Shall operate as intended after recovering. Shall be no degradation of performance (see note 2).
<p>NOTE 1: Degradation of performance during the test is understood as a degradation to a level not below a minimum performance level specified by the manufacturer for the use of the apparatus as intended. In some cases the specified minimum performance level may be replaced by a permissible degradation of performance. If the minimum performance level or the permissible performance degradation is not specified by the manufacturer then either of these may be derived from the product description and documentation (including leaflets and advertising) and what the user may reasonably expect from the apparatus if used as intended.</p> <p>NOTE 2: No degradation of performance after the test is understood as no degradation below a minimum performance level specified by the manufacturer for the use of the apparatus as intended. In some cases the specified minimum performance level may be replaced by a permissible degradation of performance. After the test no change of actual operating data or user retrievable data is allowed. If the minimum performance level or the permissible performance degradation is not specified by the manufacturer then either of these may be derived from the product description and documentation (including leaflets and advertising) and what the user may reasonably expect from the apparatus if used as intended.</p>		

7.3 Deviations from the standard

No deviations from EN 55014-2 were made when performing the tests described in this report.

8- IMMUNITY TEST RESULTS

8.1 Electrostatic Discharge Immunity Test

8.1.1 Test Specification

Basic Standard:	EN 61000-4-2:2009
Test Level:	± 8 kV (Air Discharge) ± 4 kV (Contact Discharge) ± 4 kV (Indirect Contact HCP) ± 4 kV (Indirect Contact VCP)
Temperature:	25.1 (°C)
Humidity:	55 (%RH)
Barometric Pressure:	990~1030 (mbar)
Operating Mode:	Mode1

8.1.2 Test Setup

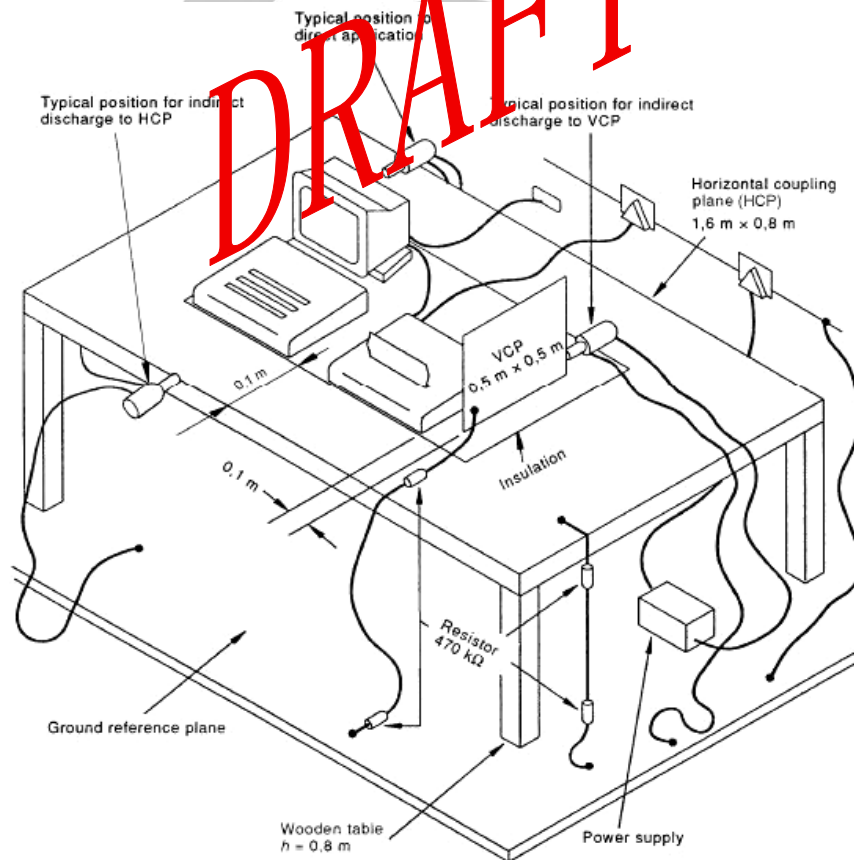

8.1.3 Test Procedure

1. Electrostatic discharges were applied only to those points and surfaces of the EUT that are accessible to users during Full load.
2. The test was performed with at least ten single discharges on the pre-selected points in the most sensitive polarity.
3. The time interval between two successive single discharges was at least 1 second.
4. The ESD generator was held perpendicularly to the surface to which the discharge was applied and the return cable was at least 0.2 meters from the EUT.
5. Contact discharges were applied to the non-insulating coating, with the pointed tip of the generator penetrating the coating and contacting the conducting substrate.
6. Air discharges were applied with the round discharge tip of the discharge electrode approaching the EUT as fast as possible (without causing mechanical damage) to touch the EUT. After each discharge, the ESD generator was removed from the EUT and re-triggered for a new single discharge. The test was repeated until all discharges were complete.
7. At least ten single discharges (in the most sensitive polarity) were applied to the Horizontal Coupling Plane at points on each side of the EUT. The ESD generator was positioned horizontally at a distance of 0.1 meters from the EUT with the discharge electrode touching the HCP.
8. At least ten single discharges (in the most sensitive polarity) were applied to the center of one vertical edge of the Vertical Coupling Plane in sufficiently different positions that the four faces of the EUT were completely illuminated. The VCP (dimensions 0.5m x 0.5m) was placed vertically to and 0.1 meters from the EUT.

8.1.4 Performance Criterion Required & Test Result

Table 1: Electrostatic Discharge Immunity (Air Discharge)

Test Level			Test Points	Observation Performance	Criterion Required
±2 kV	±4kV	±8kV			
<input type="checkbox"/>	<input type="checkbox"/>	<input checked="" type="checkbox"/>	Gap	B	B
<input type="checkbox"/>	<input type="checkbox"/>	<input checked="" type="checkbox"/>	Key	B	B
<input type="checkbox"/>	<input type="checkbox"/>	<input checked="" type="checkbox"/>	Other port	B	B
<input type="checkbox"/>	<input type="checkbox"/>	<input checked="" type="checkbox"/>	/	/	B

Table 2: Electrostatic Discharge Immunity (Direct Contact)

Test Level			Test Points	Observation Performance	Criterion Required
±2 kV	±4kV	±8kV			
<input type="checkbox"/>	<input checked="" type="checkbox"/>	<input type="checkbox"/>	metal	B	B
<input type="checkbox"/>	<input checked="" type="checkbox"/>	<input type="checkbox"/>	screw	B	B

Table 3: Electrostatic Discharge Immunity (Indirect Contact HCP)

Test Level			Test Points	Observation Performance	Criterion Required
±2 kV	±4kV	±8kV			
<input type="checkbox"/>	<input checked="" type="checkbox"/>	<input type="checkbox"/>	Front Side	B	B
<input type="checkbox"/>	<input checked="" type="checkbox"/>	<input type="checkbox"/>	Back Side	B	B
<input type="checkbox"/>	<input checked="" type="checkbox"/>	<input type="checkbox"/>	Left Side	B	B
<input type="checkbox"/>	<input checked="" type="checkbox"/>	<input type="checkbox"/>	Right Side	B	B

Table 4: Electrostatic Discharge Immunity (Indirect Contact VCP)

Test Level			Test Points	Observation Performance	Criterion Required
±2 kV	±4kV	±8kV			
<input type="checkbox"/>	<input checked="" type="checkbox"/>	<input type="checkbox"/>	Front Side	B	B
<input type="checkbox"/>	<input checked="" type="checkbox"/>	<input type="checkbox"/>	Back Side	B	B
<input type="checkbox"/>	<input checked="" type="checkbox"/>	<input type="checkbox"/>	Left Side	B	B
<input type="checkbox"/>	<input checked="" type="checkbox"/>	<input type="checkbox"/>	Right Side	B	B

Test Result: Passed Not Applicable

8.2 Electrical Fast Transient/Burst Immunity Test

8.2.1 Test Specification

Basic Standard :	EN 61000-4-4:2012
Test Level:	±1 kV for AC Power Line ±0.5 kV for Communication Line (If applicable)
Impulse Frequency:	5kHz
Impulse Wave-shape:	5/50ns
Burst Duration:	15ms
Burst Period:	300ms
Test Duration:	1 min.
Temperature:	24.5 (°C)
Humidity:	52(%RH)
Barometric Pressure:	990~1030 (mbar)
Operating Mode:	Mode1

8.2.2 Test Setup

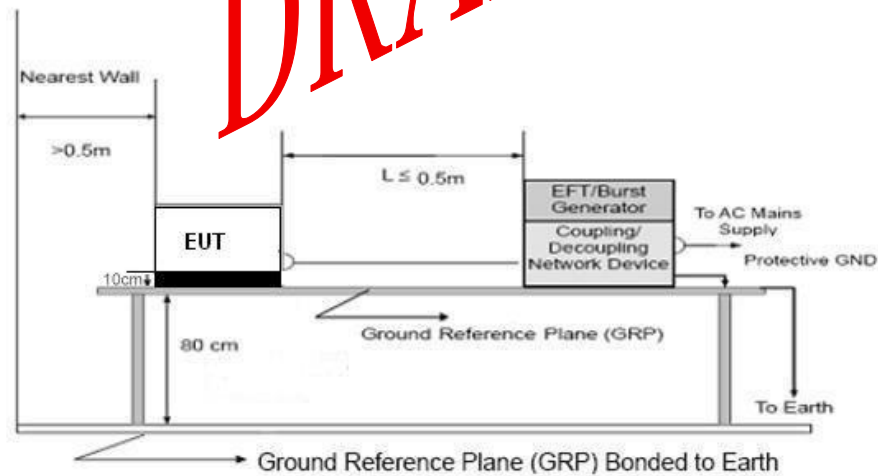

8.2.3 Test Procedure

1. Both positive and negative polarity discharges were applied.
2. The length of the “hot wire” from the coaxial output of the EFT generator to the terminals on the EUT should be 0.5m.
3. The duration time of each test sequential was 1 minute.
4. The field strength level was 3V/m.
5. The transient/burst waveform was in accordance with EN 61000-4-4, 5/50ns.

8.2.4 Performance Criterion Required & Test Result

Voltage	Test Points	Observation Performance	Criterion Required
±1kV	N	B	B
±1kV	L1	B	B
±1kV	L2	B	B
±2kV	L3	B	B

Test Result:

- Passed
 Not Applicable

DRAFT

8.3 Surge Immunity Test

8.3.1 Test Specification

Basic Standard :	EN 61000-4-5:2014+A1:2017
Test Level:	± 1 kV (Line to Line) for AC Power Line $\pm 1, 2$ kV (Line(s) to Ground) for AC Power Line
Wave-Shape:	Combination Wave 1.2/50 us Open Circuit Voltage 8/20 us Short Circuit Current
Generator Impedance:	42 ohm between signal line and ground 2 ohm between networks
Phase Angle:	90°/270°
Pulse Repetition Rate:	1 time / min
Number of Tests:	5 positive and 5 negative at selected points
Temperature:	24.5(°C)
Humidity:	52 (%RH)
Barometric Pressure:	990~1030 m bar
Operating Mode:	Mode1

8.3.2 Test Setup

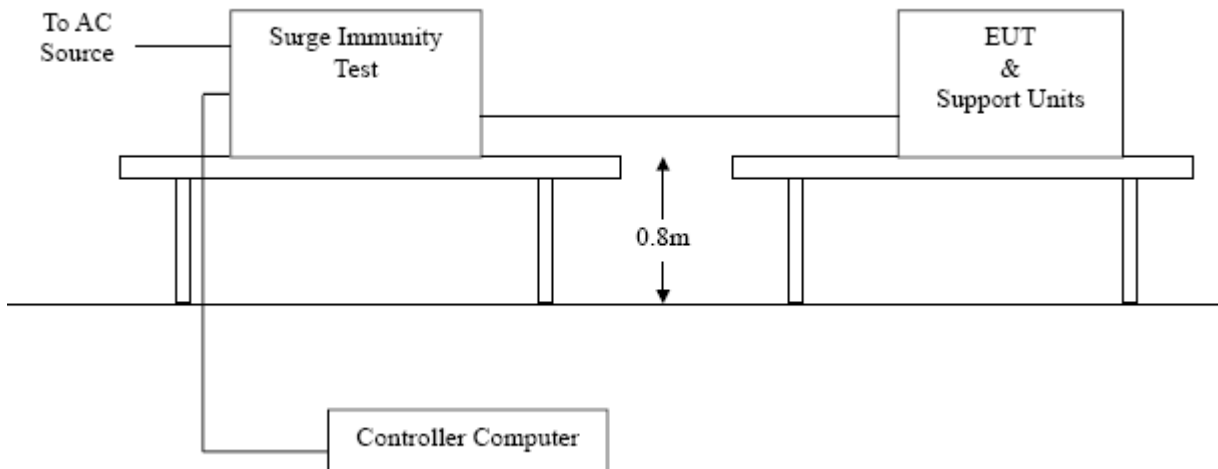

8.3.3 Test Procedure

1. For EUT power supply:

The surge is applied to the EUT power supply terminals via the capacitive coupling network. Decoupling networks are required in order to avoid possible adverse effects on equipment not under test that may be powered by the same lines, and to provide sufficient decoupling impedance to the surge wave. The power cord between the EUT and the coupling/decoupling networks was shorter than 2 meters in length.

2. For test applied to unshielded unsymmetrically operated interconnection lines of EUT: (If applicable)

The surge was applied to the lines via the capacitive coupling. The coupling / decoupling networks didn't influence the specified functional conditions of the EUT. The interconnection line between the EUT and the coupling/decoupling networks was shorter than 2 meters in length.

8.3.4 Performance Criterion Required & Test Result

Voltage	Test Points	Observation Performance	Criterion Required
±1kV	N	B	B
±1kV	L1	B	B
±1kV	L2	B	B
±1kV	L3	B	B

Test Result:

Passed Not Applicable

8.4 Conducted Susceptibility Test

8.4.1 Test Specification

Basic Standard:	EN IEC 61000-4-6:2023
Test Level:	3Vr.m.s
Frequency Range:	0.15~230MHz (MHz)
Modulation:	Amplitude 80%, 1kHz sinewave
Frequency Step:	1 % of preceding frequency value
Temperature:	24.5 (°C)
Humidity:	52 (%RH)
Barometric Pressure:	990~1030 (mbar)
Operating Mode:	Mode1

8.4.2 Test Setup

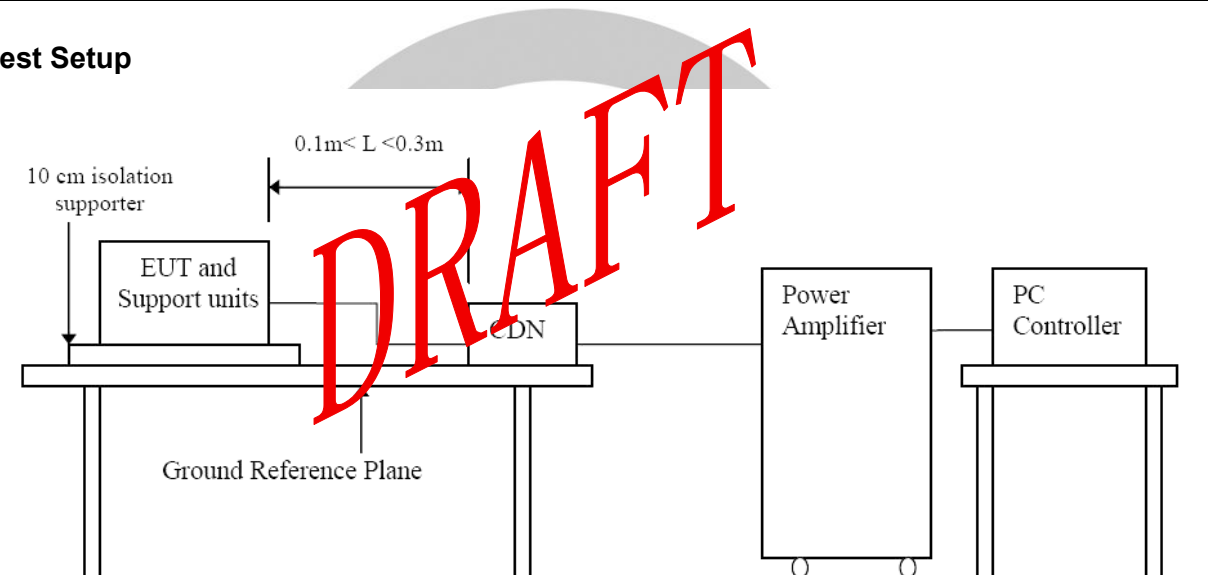

8.4.3 Test Procedure

1. The test was performed with the test generator connected to each of the coupling and decoupling devices in turn, while the other non-excited RF input ports of the coupling devices are terminated by a 50-ohm load resistor.
2. The frequency range was swept from 150 kHz to 230 MHz, using the signal level established during the setting process and with a disturbance signal of 80 % amplitude. The signal was modulated with a 1 kHz sine wave, pausing to adjust the RF signal level or the switch coupling devices as necessary. The sweep rate was 1.5×10^{-3} decades/s. Where the frequency range is swept incrementally, the step size was 1 % of preceding frequency value from 150 kHz to 230 MHz.

3. The dwell time at each frequency was less than the time necessary for the EUT to be exercised, and able to respond. Sensitive frequencies such as clock frequency(ies) and harmonics or frequencies of dominant interest, was analyzed separately.
4. Attempts was made to fully exercise the EUT during testing, and to fully interrogate all exercise modes selected for susceptibility.

8.4.4 Performance Criterion Required & Test Result

Frequency Band (MHz)	Voltage (Vrms)	Test Points	Observation Performance	Criterion Required
0.15-230	3	AC Port	A	A

Test Result:

Passed Not Applicable

DRAFT

8.5 Voltage Dips, Short Interruptions Immunity Tests

8.5.1 Test Specification

Basic Standard:	EN IEC 61000-4-11:2020/AC:2022
Test Level:	Voltage Dips: 1) 0% residual voltage for 0.5 cycle for 50/60Hz. 2) 70% residual voltage for 10/12 cycles for 50/60Hz. Voltage Interruptions: 3) 0% residual voltage for 25/30 cycles for 50/60Hz.
Interval between event:	10 seconds
Phase Angle:	0°/180°
Test cycle:	3 times
Temperature:	24.5(°C)
Humidity:	52(%RH)
Barometric Pressure:	990~1030 (mbar)
Operating Mode:	Mode1

8.5.2 Test Setup

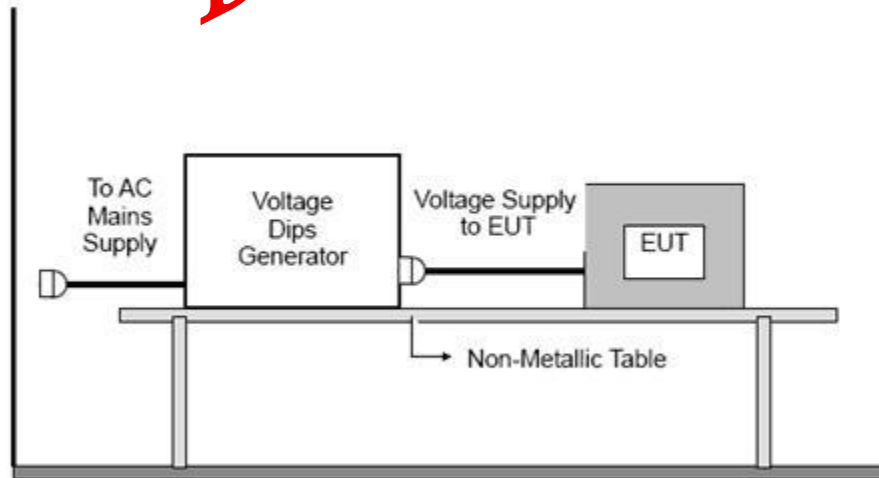

8.5.3 Test Procedure

The EUT was tested for each selected combination of test levels and duration with a sequence of 3 dips/interruptions with intervals of 10s (between each test event). Each representative mode of operation shall be tested. Abrupt changes in supply voltage shall occur at zero crossings of the voltage waveform.

8.5.4 Performance Criterion Required & Test Result

Ut: 380V AC, 50Hz			
Voltage (% Residual)	Duration (Period)	Observation Performance	Criterion Required
0	0.5	B	B
40	12	B	B
70	25	B	B
95	250	C	C

Test Result:

Passed Not Applicable

DRAFT

8.6 Radiated Susceptibility Test

8.6.1 Test Specification

Basic Standard:	EN IEC 61000-4-3:2020
Frequency Range:	80~1000MHz
Modulation:	Amplitude 80%, 1kHz sinewave
Test Level:	3V/m
Temperature:	24.5 (°C)
Humidity:	52 (%RH)
Barometric Pressure:	990~1030 (mbar)
Operating Mode:	Mode1

8.6.2 Test Setup

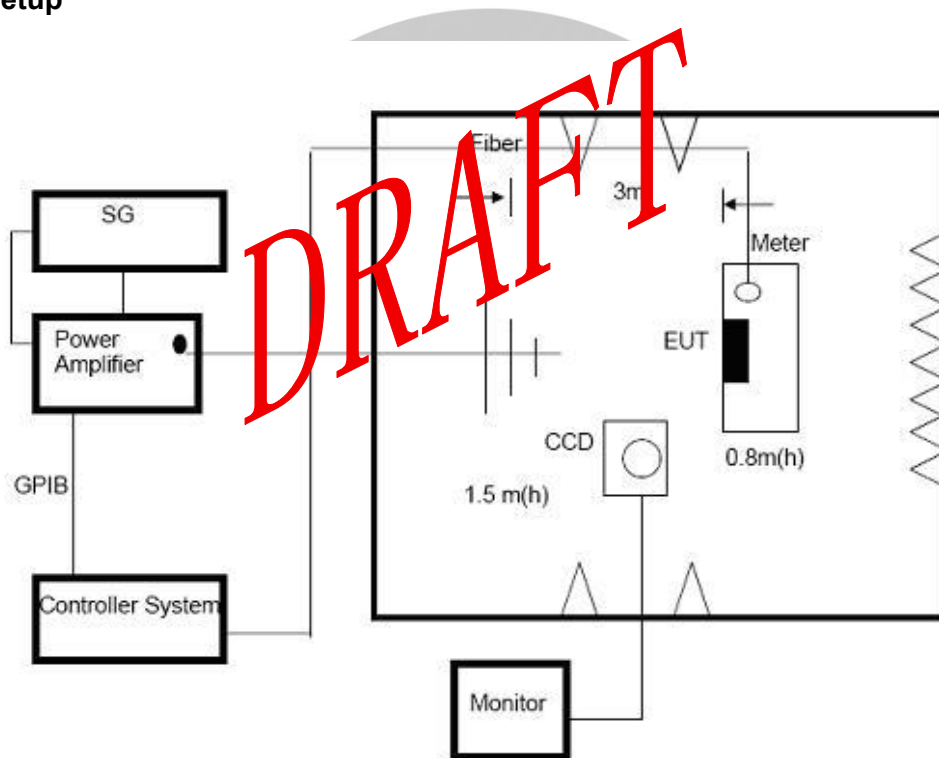

8.6.3 Test Procedure

1. The testing was performed in a fully-anechoic chamber.
2. The frequency range is swept from 80 MHz to 1000 MHz, with the signal 80% amplitude modulated with a 1kHz sine wave.
3. The dwell time at each frequency shall not be less than the time necessary for the EUT to be exercised and to respond, but shall in no case be less than 0,5s.

4. The field strength level was 3V/m.
5. The test was performed with the EUT exposed to both vertically and horizontally polarized fields on each of the four sides.

8.6.4 Performance Criterion Required & Test Result

Frequency Band (MHz)	Test Level	Test Points	Observation Performance	Criterion Required
80-1000	3V/m	Front Side	A	A
80-1000	3V/m	Rear Side	A	A
80-1000	3V/m	Left Side	A	A
80-1000	3V/m	Right Side	A	A

Test Result: Pass

DRAFT

APPENDIX A - EUT PHOTOGRAPHS



Photo 1



Photo 2

***** END OF REPORT *****